

MERLO P34.7



MARSH PLANT®

NEW LANE, HAVANT, HAMPSHIRE, PO9 2LZ
Telephone 023 9248 2323

Millbrook Road, Southampton
Hampshire, SO15 0LB
Telephone 023 8052 2600
southampton@marshplant.com

www.marshplant.com

Drakes Drive, longCrendon
Aylesbury, HP18 9BA
Telephone 01844 204000
longcrendon@marshplant.com

Cabot Lane, Creekmoor, Poole
Dorset BH17 7BX
Telephone 01202 642820
poole@marshplant.com

7b Watercombe Park
Gazelle Road, Yeovil
Somerset, BA20 2HL
Telephone 01935 415970
yeovil@marshplant.com

Wallingford Road, Uxbridge
Middlesex UB8 2SS
Telephone 01844 204000
longcrendon@marshplant.com

TURBOFARMER P 34.7

TECHNICAL DATA

P 34.7 PLUS / P 34.7 TOP



COMPLIANT EN 15000

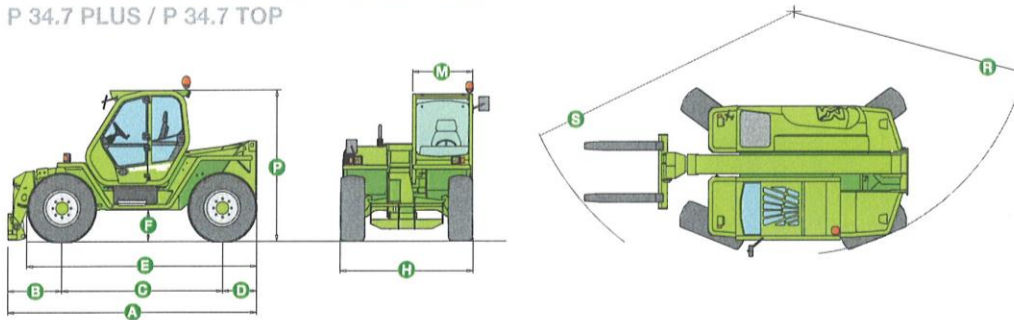

DIMENSIONS	P 34.7
A (mm)	4330
B (mm)	1025
C (mm)	2700
D (mm)	605
E (mm)	3865
F (mm)	565
H (mm)	2230
M (mm)	995
P (mm)	2475
R (mm)	3985
S (mm)	4800

BSS – TELESCOPIC BOOM SUSPENSION

The **BSS (Boom Suspension System)** system relies on simple and reliable technology to offer effective absorption of the stress and vibrations transmitted to the load during handling and transport operations.

An hydraulic circuit with pneumatic pressure dampers controls the system, and allows the jolts of the telescopic boom to be significantly reduced while driving either at high speed or on uneven terrain.

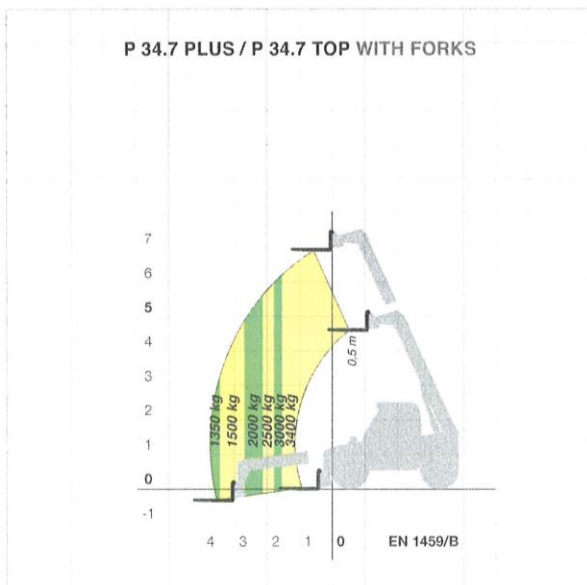

CHARACTERISTICS AND PERFORMANCE	P 34.7
Total weight unladen, with forks (kg)	6750
Maximum load capacity (kg)	3400
Maximum lift height (m)	7,1
Maximum forward reach (m)	3,7
Lift height at maximum load capacity (m)	7,1
Forward reach at maximum load capacity (m)	1,5
Load capacity at maximum lift height (kg)	3400
Load capacity at maximum forward reach (kg)	1350
Boom side-shift (mm)	-
Frame levelling (%)	-
Turbocharged engine (make/cylinder)	Deutz/4
Tier 3 engine power (kW/HP)	88/120 ⁽¹⁾
Speed in 1 st gear (kph)	16
Speed in 2 nd gear (kph)	40
EAS hydropneumatic suspension	-
Fuel tank capacity (l)	150
Gear pump hydraulic system (bar-l/min)	210-102 ⁽²⁾
Load-Sensing hydraulic system (bar-l/min)	210-132 ⁽³⁾
LS Flow-Sharing hydraulic system (bar-l/min)	-
Hydraulic oil capacity (l)	105
Electrical circuit (V)	12
Battery (Ah)	100
FOPS (ISO 3449) and ROPS (ISO 3471) cab	●
CS hydropneumatic suspension	-
Electro-mechanical joystick control	●
Electronic joystick control	-
Tac-Lock attachment coupling	●
Auxiliary boom hydraulic service	●
Two floating forks (length 1200 mm)	●
Hydrostatic transmission	●
Finger-Touch direction reversing control	●
Inching-Control	●
Permanent four-wheel drive	●
Four-wheel steering	●
Automatically locking parking brake	●
Four cab working lights (2 F + 2 R)	●
Manual battery isolator	●
Tyres	405/70-24
BSS hydropneumatic suspension	○
Shift-on-the-Go synchronised gearbox	○
Differential lock (F + R or only R)	○
Manual air conditioning system	○
Two additional working lights on the boom	○
European tractor type approval	○

● Standard. ○ Optional
 (1) Top model. 74,9 kW (102 HP) on Plus model; (2) Plus model; (3) Top model.